

RT 70 / AP
70 LBS THRUST
24 VOLT 42 AMPS
54" SHAFT

for use with "K" serial numbers

2-year warranty from the date of purchase

Click here to order parts. www.warnersdock.com 888/222-3625

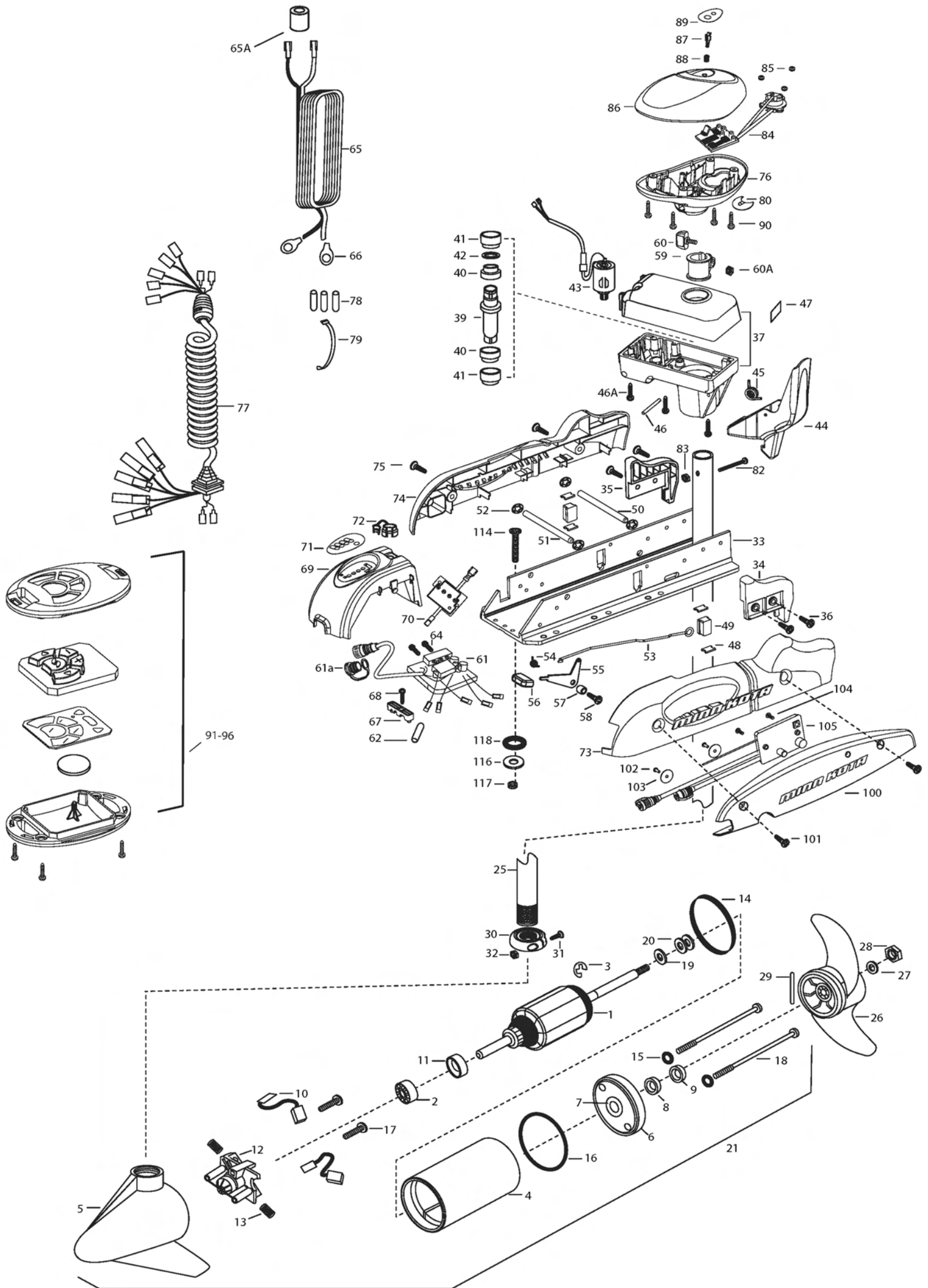

| | | | | | | | | |
|-----|-----------|---|-----|---------|----------------------------------|------|---------|----------------------------------|
| 1 | 2-100-119 | ARMATURE ASSEMBLY 24V VARS TXT | *41 | 2307305 | BUSHING- OUTER [2.EA] | 80 | 2224703 | INSERT- PLUG WHITE |
| 2 | 140-010 | BALL BEARING | *42 | 2304603 | O-RING | 82 | 2332102 | SCREW-10-24 X 1-3/4 |
| 3 | 788-015 | RETAINING RING | 43 | 2307050 | MOTOR- DRIVE HOUSING HIGH SPD | 83 | 2333101 | NUT-HEX 10-24 NYLOC |
| 4 | 2-200-304 | HOUSING ASSEMBLY CENTER 3.62 TXT | 44 | 2307201 | LATCH HANDLE PD/AP | 84 | 2994014 | CNTRL BOARD/AP COMPASS ASSEMBLY |
| 5 | 421-336 | HOUSING -BRUSH END 3.62 TXT | 45 | 2302750 | SPRING- LATCH TORSION PD/AP | | 2994015 | COMPASS BOARD, SOUT HEMISPHERE |
| 6 | 2-400-337 | PLAIN END HOUSING ASSEMBLY 3.625 | 46 | 2302628 | PIN- ROLL 3/16X2 SS | 85 | 2302960 | GROMMET-COMPASS [3.EA] |
| 7 | 144-049 | BEARING - FLANGE (SERVICE ONLY) | 46A | 2303405 | SCREW - DRIVE HOUSING [6 EA] | 86 | 2300243 | CONTROL BOX COVER- RIPTIDE WHITE |
| 8 | 880-003 | SEAL | 47 | 2305564 | DECAL-STOW/DEPLOY | 87 | 2304082 | ACTUATOR- SWITCH ON/OFF A/P |
| 9 | 880-006 | SEAL WITH SHIELD | 48 | 2305110 | PAD-PIVOT SUPT [4.EA] | 88 | 2303752 | SPRING- ACTUATOR PD/AP SS |
| 10 | 188-037 | BRUSH ASSEMBLY [2.EA] | 49 | 2305103 | PIVOT PAD- NEW MTR'L [2.EA] | 89 | 2305656 | DECAL- COVER 70 pd/ap |
| 11 | 725-050 | BRUSH RETENTION- PAPER TUBE | 50 | 2330510 | PIN-LATCH PD BASE SS | 90 | 2372100 | SCREW-8-18 X 5/8 THD CUT [4.EA] |
| 12 | 738-036 | BRUSH PLATE W/HOLDER | 51 | 2330520 | PIN-PIVOT PD BASE SS | | | |
| 13 | 975-040 | SPRING - TORSION [2.EA] | 52 | 2013100 | NUT-SPEED [4.EA] | ■ | 2994020 | COPILOT TRANSMITTER |
| 14 | 337-036 | GASKET | 53 | 2303612 | ROD-RELEASE RT/AP S | 91 | | CASE, COVER, TRANSMITTER |
| 15 | 701-008 | O-RING, THRU-BOLT [2.EA] | 54 | 2322700 | SPRING-RELEASE LEVER | 92 | | KEYPAD |
| 16 | 701-081 | O-RING | 55 | 2333705 | LEVER-RELEASE SS | 93 | | CIRCUIT BOARD, TRANSMITTER |
| 17 | 830-007 | SCREW-8-32 [2.EA] | 56 | 2300101 | RELEASE-KNOB | 94 | | BATTERY, COIN |
| 18 | 830-042 | THRU-BOLT 10-32X8.83 [2.EA] | 57 | 2301700 | SPACER-RELEASE LEVER | 95 | | CASE, BOTTOM, TRANSMITTER |
| 19 | 990-067 | WASHER- STEEL THRUST | 58 | 2332104 | SCREW-1/4-20 X 5/8 SS | 96 | | SCREW, TRANSMITTER [4EA] |
| 20 | 990-070 | WASHER - NYLATRON [2.EA] | 59 | 2031522 | COLLAR- DRIVE (W/INSERT) | ■ | 2994089 | RECEIVER ASSEMBLY V2, COPILOT |
| 21 | 2096036 | MOTOR ASSEMBLY 24V 3.62 | 60 | 2011366 | SCREW-COLLAR/NEW KNOB SS | 100 | 2372511 | CASE, RECEIVER WHT |
| 25 | 2032021 | TUBE- COMPOSITE WHT 48" | 60A | 2323104 | NUT | 101 | 2373442 | SCREW 1/4-20 X 1.75 SS [2EA] |
| | 2032022 | TUBE- COMPOSITE WHT 54" | 61 | 2304063 | CONTROL BOARD ASSEMBLY- 24V PD | 102 | 2373450 | SCREW #8 X 3/8 [2EA] |
| | 2032025 | TUBE- COMPOSITE WHT 60" | 61a | 2320208 | DUST PLUG | 103 | 2371727 | WASHER [2EA] |
| ■ | 1378131 | PROPELLER KIT | 62 | 2355403 | SHRINK TUBE-3/8 ODX2 | 104 | 2373418 | SCREW #8 X 5/8 SS |
| 26 | 2091160 | PROPELLER W/WEDGE 2 | 64 | 2303434 | SCREW-8-32 X 5/8 [3.EA] | 105 | 2374089 | CIRCUIT BOARD V2, RECEIVER |
| 27 | 2151726 | WASHER-5/16 SS | 65 | 2090651 | LEADWIRE IOGA 44" | ■ | 2994864 | BAG ASSEMBLY- (BOLT,NUT,WASHERS) |
| 28 | 2198400 | ANODE- ZINC 3.25/3.625 LWR U | 65A | 2307310 | BEAD - FERRITE (CE MODELS ONLY) | *114 | 2263462 | BOLT-MOUNTING-1/4X2 W/STG [6.EA] |
| 29 | 2092600 | PIN-DRIVE | 66 | 2020700 | TERMINAL RING [2.EA] | *116 | 2261713 | WASHER-1/4 [6.EA] |
| 30 | 2301545 | COLLAR- LATCH PD/AP | 67 | 2321310 | STRAIN RELIEF- BRACKET PD/AP | *117 | 2263103 | NUT NYLOK 1/4-20 MTG [6.EA] |
| 31 | 2303434 | SCREW- 8-32X5/8 MACH PHCR | 68 | 2323405 | SCREW-1/4-20 X 5/8 SS | *118 | 2301720 | WASHER-MOUNTING RUBBER [6.EA] |
| 32 | 2303112 | NUT 8-32 NYLOC SS | 69 | 2306556 | HOUSING- CENTER PD/AP WHIT | | | |
| 33 | 2301937 | EXTRUSION- BASE MACHINED | 70 | 2074081 | BATTERY GAUGE - 24 VOLT | ■ | 2888460 | SEAL & ORING KIT |
| 34 | 2303932 | MOTOR REST- RIGHT 3-5/8 | 71 | 2316606 | DECAL- BATT GAUGE H RT AP | | | |
| 35 | 2303937 | MOTOR REST- LEFT 3-5/8 | 72 | 2302935 | STRAIN RELIEF-DR. HOUSING | | | |
| 36 | 2332104 | SCREW 1/4-20X5/8 SELF TAP [4.EA] | 73 | 2303944 | SIDEPLATE (RIGHT) WHITE | | | |
| 37 | 2771827 | DRIVE HOUSING / LATCH HANDLE WHITE | 74 | 2303949 | SIDEPLATE(LEFT) WHITE | | | |
| ■ | 2882011 | BUSHING/ OUTSHAFT KIT (INCLUDES 39-42) | 75 | 2332104 | SCREW-1/4-20 X 5/8 SS | | | |
| | | | 76 | 2302516 | CONTROL BOX WHT | | | |
| *39 | 2302010 | DRIVE HOUSING OUTPUT SHAFT | 77 | 2991285 | COIL CORD WSTRAIN RELIEF 48, 54" | | | |
| *40 | 2307304 | BUSHING- INNER [2.EA] | 78 | 2065400 | WIRE INSULATOR-LGE 1-3/4 [3.EA] | | | |
| | | | 79 | 2256300 | TIE WRAP-5" BLACK | | | |

Click here to order parts
www.warnersdock.com
888/222-3625

12-24 VOLT MODELS

MODÈLES 12-24 V

RT70 is 24-volt only!

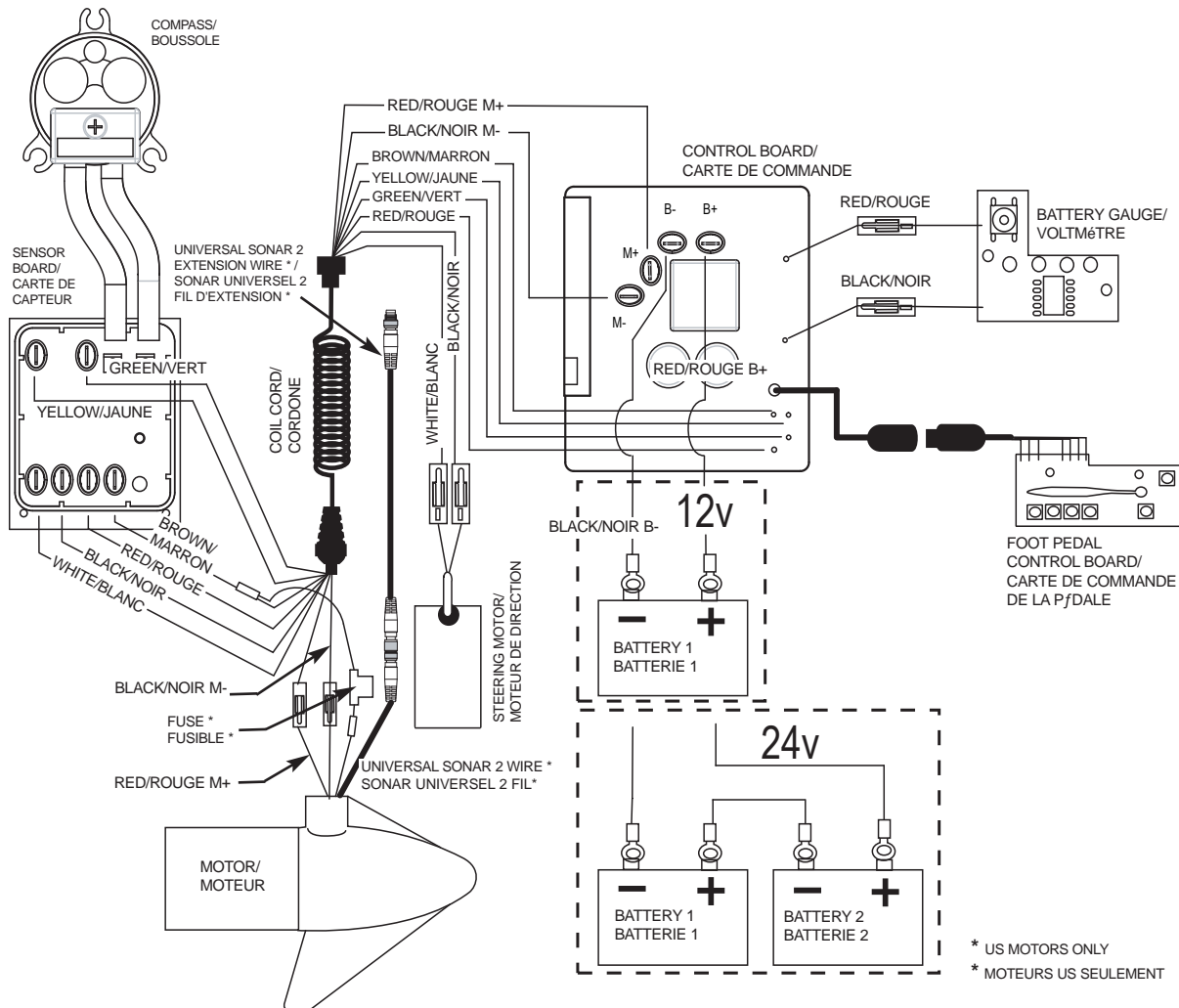

* US MOTORS ONLY
* MOTEURS US SEULEMENT