

DeckHand 25R (Remote)

2-year warranty

Click here to order parts.

[www.warnersdock.com](http://www.warnersdock.com)

888/222-3625

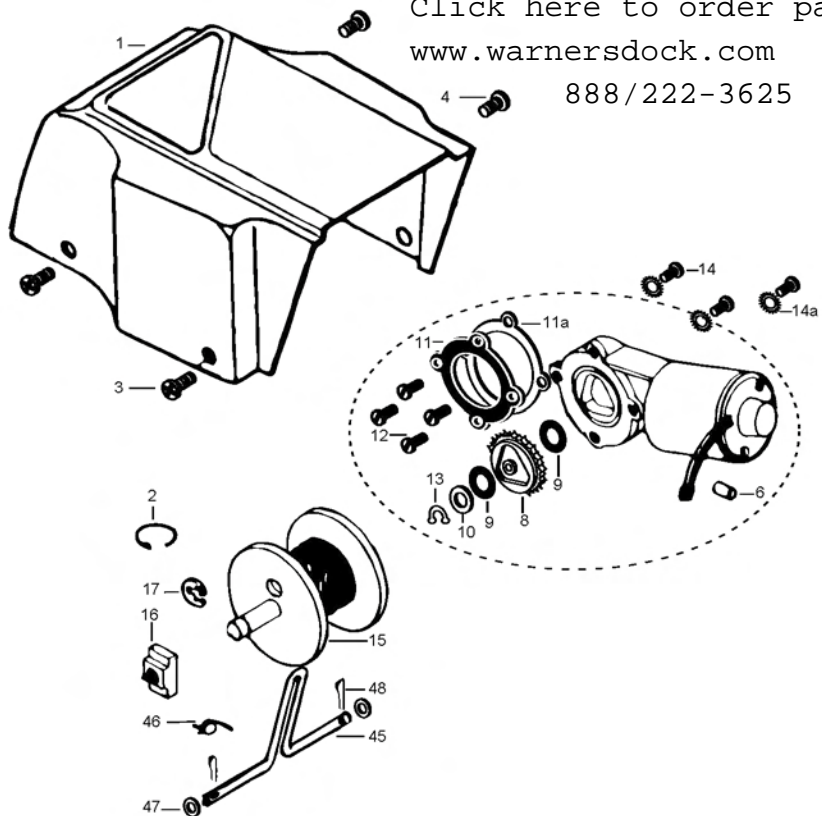

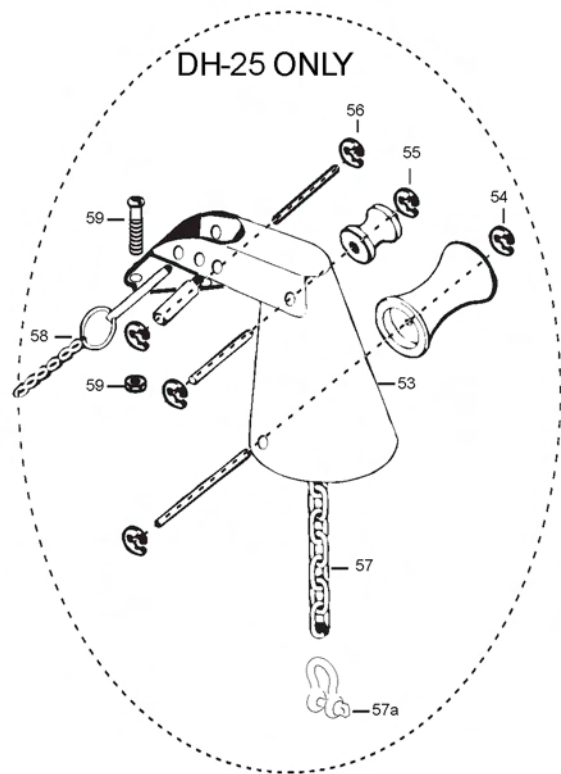
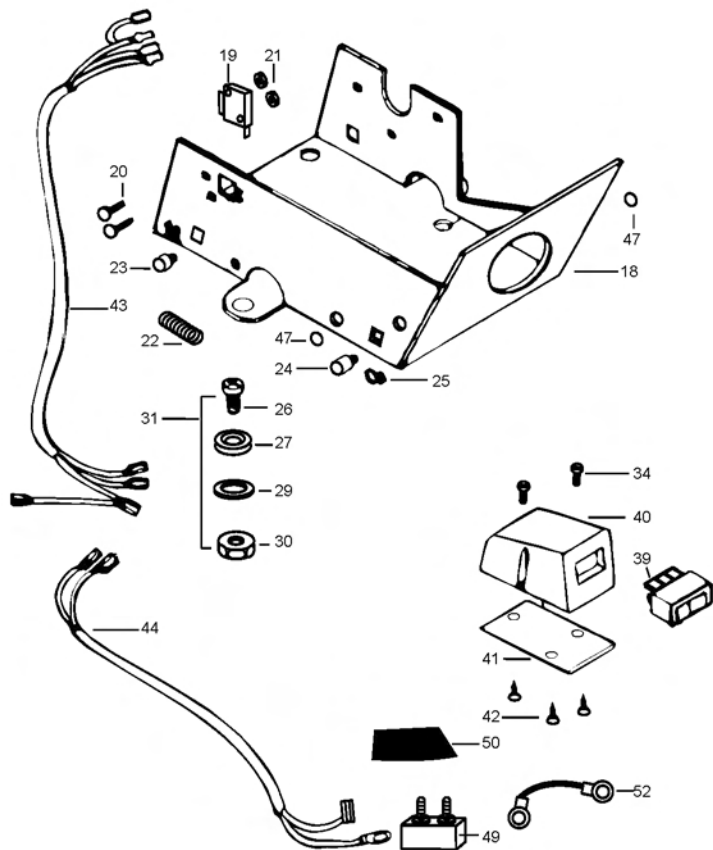

Item	Part	Description
1	237-0209	Cover DH-25R
2	230-3005	Pig Ring
3	237-2121	Screw-#8-18x 1-1/2 Stallgrd (2 .ea)
4	237-2111	Screw-#8-18x3/4 Stallgrd (2 .ea)
■	237-7803	Motor Assembly - DeckHand- Includes 6-13
6	237-5400	Shrink Tube 1/4x1-3/4 (2 .ea)
8	350-154	Gear
9	990-077	Washer - Nylatron (2 .ea)
10	990-075	Washer - Steel
11	410-015	Cover- Housing
11a	337-015	Gasket
12	830-036	Screw - 10-32x.375 (4.ea)
13	788-030	Retaining Ring
14	222-3455	Screw-#10-32x1/2 (3 .ea)
14a	226-1718	Washer- Lock Star #10 Ext Tooth 3.ea)
15	237-7900	Spool includes 60' rope
16	237-0000	Bearing-Spool
17	226-3010	E-Ring 3/8 Dia Shaft
18	237-1900	Base- Mounting E-Coat
19	237-4010	Switch-Momentary Anchor
20	237-2130	Screw-#4-40x3/4 PPH (2 .ea)
21	237-3100	Nut-Con/Mom Swt Anchor (2 .ea)
22	237-2700	Spring-Anchor
23	237-2900	Grommet-Anchor Cover Short (2 .ea)
24	237-2910	Grommet-Anchor Cover Long (2 .ea)
25	237-6300	Wire- Routing Clip (2 .ea)
■	299-4803	Bag Assembly (includes 26-30)
26	215-3501	Bolt- Mounting 3500 w/stallgd (4 .ea)
27	230-1720	Mounting Washer-Rubber (6 .ea)
29	215-1726	Washer 5/16 STD SS (4 .ea)
30	215-3100	Nut 5/16 (4 .ea)
34	237-2100	Screw, #8
39	237-4000	Switch-Control Anchor
40	237-6500	Switch Housing (DH- 25R)
41	237-6510	Switch Plate
42	237-2150	Screw-Switch Plate 6-20x1/2 (3 .ea)
43	237-0700	Control Wire (DH-25R)
44	237-0602	Leadwire (DH- 25R)
45	237-1610	Rope Guide
46	237-2710	Spring-Rope Guide
47	215-1700	Washer- Eye Shaft (2 .ea)
48	237-2615	Cotter Pin 3/32x3/4 (2 .ea)
49	237-8204	Circuit Breaker
50	237-2031	Tubing- Heat Shrink
52	237-1412	Connecting Cable 14ga
53	299-8411	Davit Assembly
54	299-2312	Large Roller Assembly
55	299-2306	Small Roller Assembly
56	299-1503	Sleeve Roller Assembly
57	237-0820	Safety Chain Assembly
57a	237-0806	Anchor Shackle
58	299-2620	Safety Pin Assembly
59	277-4805	Mounting Bolts and Nuts (4 each)

Click here to order parts. [www.warnersdock.com](http://www.warnersdock.com)  
888/222-3625

