

DeckHand 40

2-year warranty

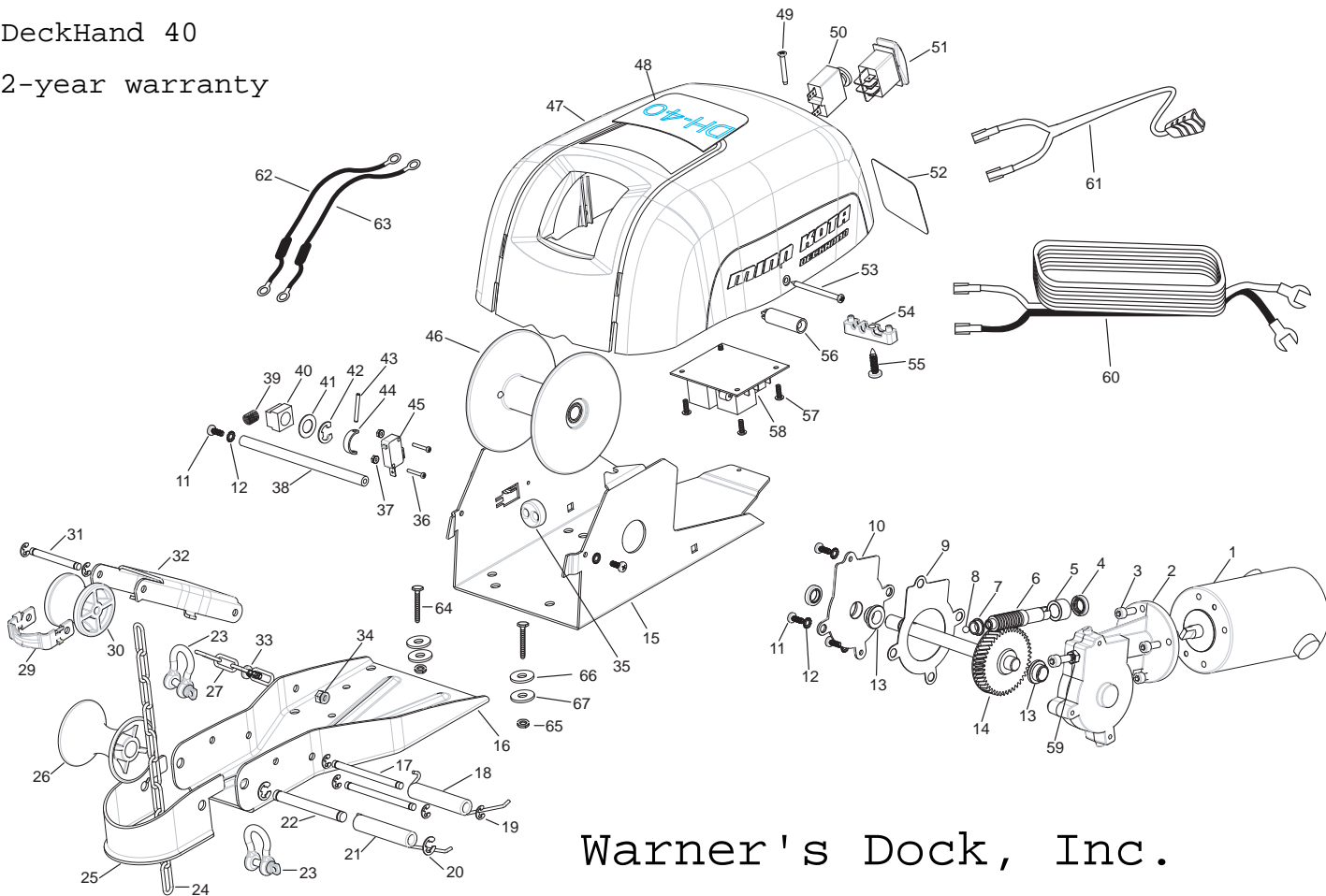

Warner's Dock, Inc.

888/222-3625

■	2997816	MOTOR/GEAR ASSEMBLY (Includes items 1-10,13,14)			
*1	2377802	MOTOR			
*2	2376502	GEAR BOX			
3	2373448	SCREW M6X1.0 X16mm [5 EA.]			
4	880-026	SEAL [2 EA.]			
5	2370041	BRONZE BUSHING			
*6	2372238	WORM GEAR			
7	2377300	BRONZE BUSHING 3/8" SHAFT			
*8	2376000	BALL-THRUST			
9	2376915	GASKET			
10	2376515	GEAR BOX COVER			
11	2223455	SCREW #10-32 X 1/2" [6 EA.]			
12	2261718	WASHER-#10 EXT. LW [6 EA.]			
13	2227304	BRONZE BUSHING 1/2" SHAFT [2 EA.]			
*14	2372254	GEAR SHAFT			
15	2371901	BASE			
■	2998410	DAVIT ASSEMBLY (Includes items 16-22, 25-34)			
*16	2376505	DAVIT CHASSIS			
17	2372607	HINGE PIN [2 EA.]			
18	2372712	TORSION SPRING			
19	2013000	E-RING [6 EA.]			
20	2263010	E-RING [2 EA.]			
21	2372713	TORSION SPRING			
22	2372606	AXLE PIN			
23	2370806	SHACKLE [2 EA.]			
24	2370820	CHAIN			
25	2371613	LOWER LINE GUIDE			
26	2372311	ROLLER-LARGE			
27	2370801	SAFETY LANYARD			
29	2371614	UPPER LINE GUIDE			
30	2372306	ROLLER-SMALL			
31	2372601	AXLE PIN			
32	2374210	LIFTING ARM			
33	2373402	SCREW-1/4-20X5/8"			
34	2263103	NUT- 1/4" NYLOC			
35	2373200	ROPE STOP			
36	2372130	SCREW-#4-40 X 3/4" [2 EA.]			
37	2373100	NUT-#4-40 KEPS [2 EA.]			
38	2371612	LINE GUIDE			
39	2372700	COIL SPRING			
40	2370001	SPOOL BEARING			
41	990-051	WASHER			
42	788-040	E-RING			
43	2092601	DRIVE PIN			
44	2372630	PIN KEEPER			
45	2374010	SWITCH			
46	2377901	SPOOL W/ROPE	59	2373105	HEX NUT M6X1.0
47	2370202	COVER	60	2090601	LEADWIRE
48	2375505	DECAL-TOP COVER	61	2370703	CONTROL CORD
49	2372123	SCREW-#8-32 X 1.25"	62	2370704	JUMPER WIRE #20GA BLUE
50	2378203	CIRCUIT BREAKER	63	2370706	JUMPER WIRE #10GA RED
51	2374001	SWITCH	■	2994853	BAG ASSEMBLY
52	2375504	DECAL- MFR. NOTICE	64	2153501	5/16" -18 BOLT [8 EA.]
53	2372122	SCREW-#10-16 X 2 1/2" [2 EA.]	65	2153100	NUT- 5/16-18" [8 EA.]
54	2222905	STRAIN RELIEF	66	2301720	WASHER RUBBER [8 EA.]
55	2373446	SCREW- 1/4-20 X 1" [2EA]	67	2151726	WASHER 5/16" [8 EA.]
56	2372920	STANDOFF [2 EA.]			
57	2372100	SCREW- #8-10 X 5/8"[4 EA.]			
58	2378225	CIRCUIT BOARD ASSEMBLY			

* This item is part of an assembly. This item cannot be sold separately due to machining and /or assembly that is required.

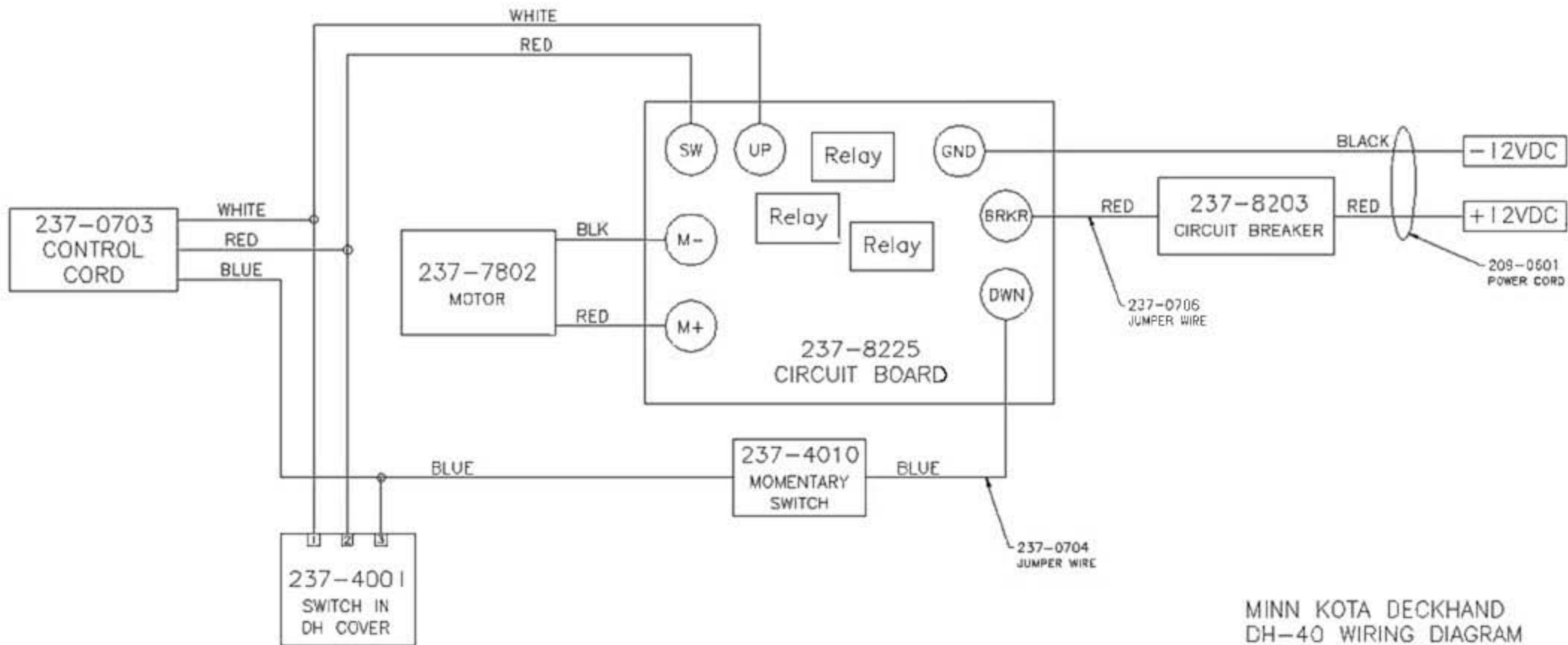

MINN KOTA DECKHAND
DH-40 WIRING DIAGRAM