

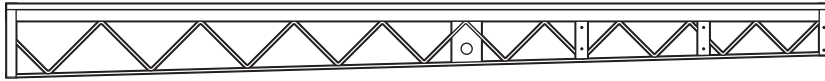

4' Roll-A-Dock™ AND ACCESSORY PARTS LIST

Substitute "S" for "A" in part numbers for steel

1 DOCK SECTION 16' – WHEEL END



1 DOCK SECTION 16' – SHORE END with 6 bolts and nuts and 2 clamps

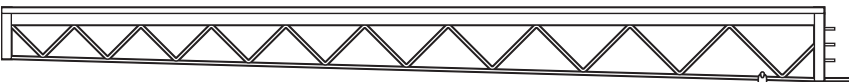

1 BUNDLE
DBUNDLES

1 - 4' PIPE NDA3206



1 - 5' AXLE PIPE NDG3207



2 - 2" X 4' FLAT STRIPS NDA3208



2 - ANGLE BRACES NDG3209



1 WHEEL ASSEMBLY
DASSYS

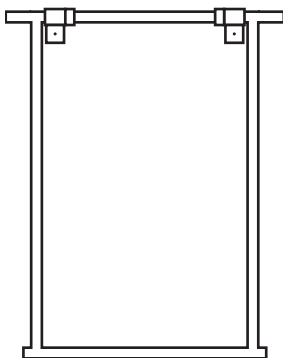

TWO TIRES
DWHEEL

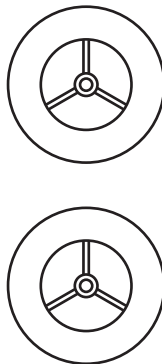

1 HARDWARE BAG & WINCH FOR 4' ROLL-A-DOCK DHDWR

- | | |
|---------------------------------------|----------------------------------|
| 1 Winch DL1100 – DWINCH | 2 1/2" x 1-1/2" Bolts – NB12112G |
| 1 Winch Instruction – WDL11 | 2 1/2" Locking Nuts – NN12L |
| 1 Dock Assembly Instruction – NAASSYD | 6 Cotter Pins – NCP |
| 1 Winch Bolt Bag – DWINCHB | 2 3/8" x 1" Bolts – NB381G |
| 1 1/4" Cable 24' Long – DCABLE | 2 3/8" Nuts – NN38S |
| 1 1/4" Cable Clamp – LICC1/4 | 5 5/16" x 1" Bolts –NB5161G |
| 2 2" Sheaves – LIPS2 | 5 5/16" Nuts –NN516S |
| 1 Dock Crank Handle –DHANDLE | 2 Tire Washers – DTW |
| 1 Crank Handle Hole Plug –DPLUG | |

OPTIONAL
DEEP WATER KIT
DDEEP

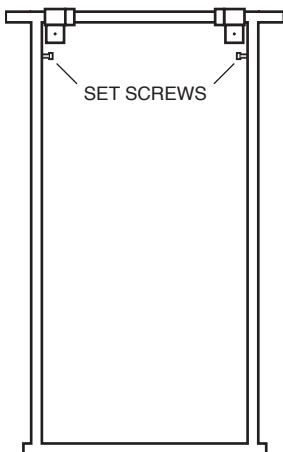

"L" SECTION with 8 bolts and nuts
4' or 8' lengths

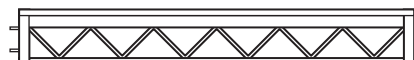

EXTENSIONS with 6 bolts and nuts and 2 clamps
4', 8' or 16' lengths



SUPPORT
STAND BRACKET
DABRAC



STANDARD 5'
STAND PIPE
DAP5

MUD PAD
DAMUD

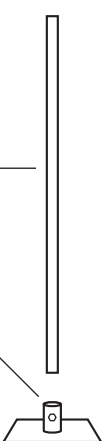

"Quality Since 1971"

HEWITT MACHINE & MFG, INC. Box 111 Nicollet, MN 56074 (507) 225-3421

www.hewitt-roll-a-dock.com e-mail: info@hewitt-roll-a-dock.com



Roll-A-Dock™ ACCESSORIES

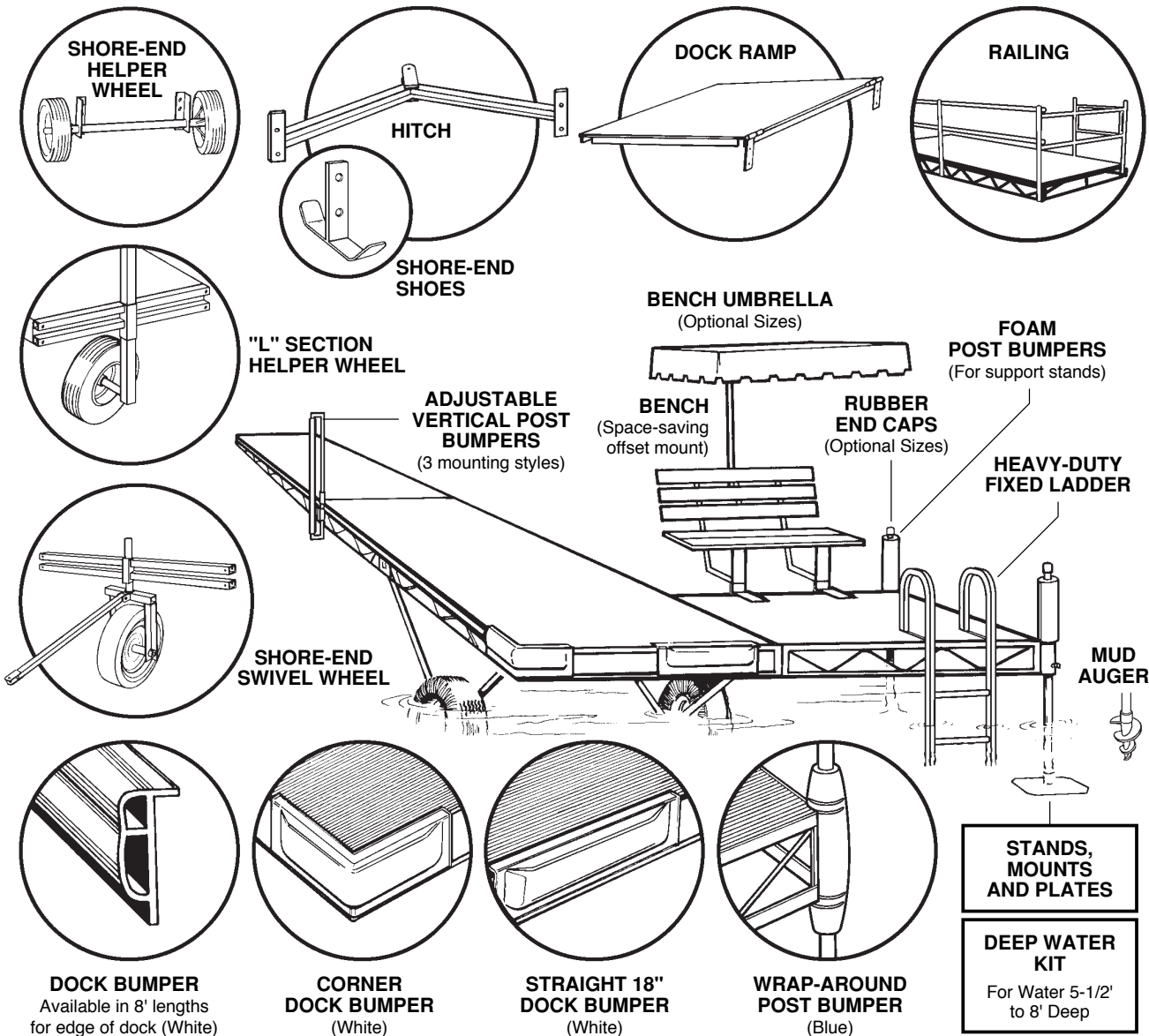

DOCK BUMPER
Available in 8' lengths
for edge of dock (White)

CORNER DOCK BUMPER
(White)

STRAIGHT 18" DOCK BUMPER
(White)

WRAP-AROUND POST BUMPER
(Blue)

STANDS, MOUNTS AND PLATES

DEEP WATER KIT
For Water 5-1/2' to 8' Deep

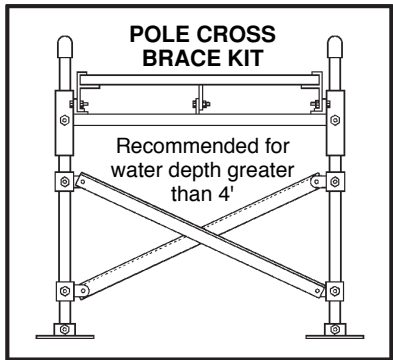
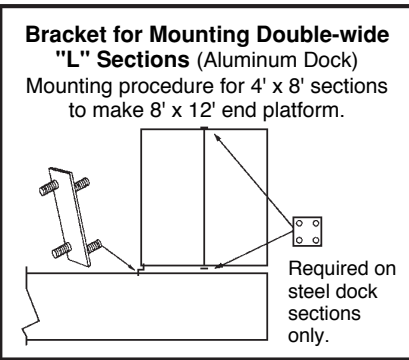
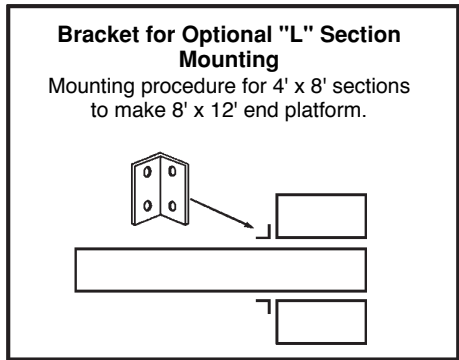

"Quality Since 1971"

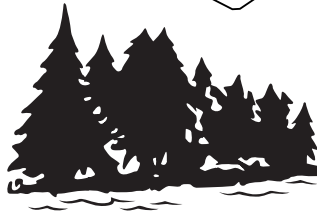

HEWITT

ASSEMBLY INSTRUCTIONS

Attention: If placing dock in deeper water, contact dealer, a deep water kit may be needed.

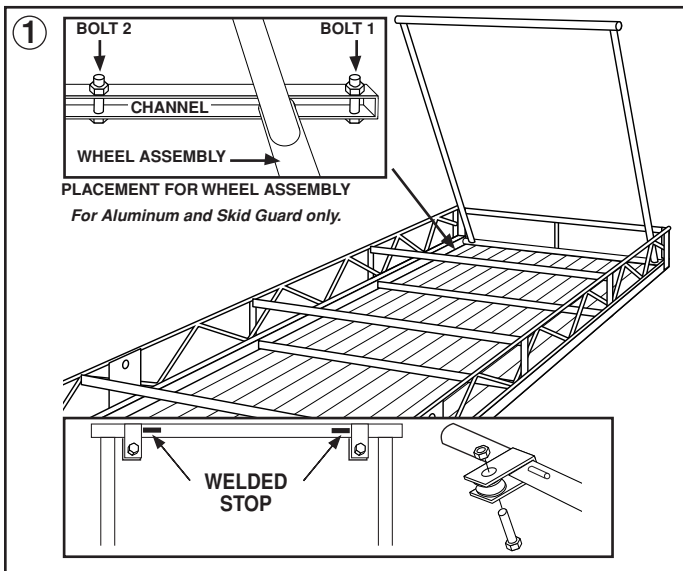

- Lay dock upside down on the ground.
- Assemble 2" pulley sheaves into bracket on wheel assembly with 1/2" x 1-1/2" bolts and lock nuts. The Nut end of bolt should be away from decking.
Note: Sheaves should turn freely.
- Turn wheel assembly at an angle, place in channel and straighten as shown in diagram above.
- The wheel assembly slides freely in channel between the first two bolts going through the channels (see diagram above).
Note: If not placed between these bolts it will not slide properly.

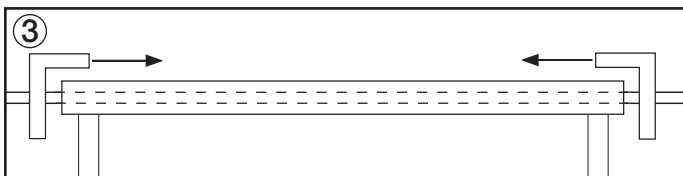

- Insert axle pipe through the larger pipe on wheel assembly.
- Slide angled braces over axle up to the wheel assembly.

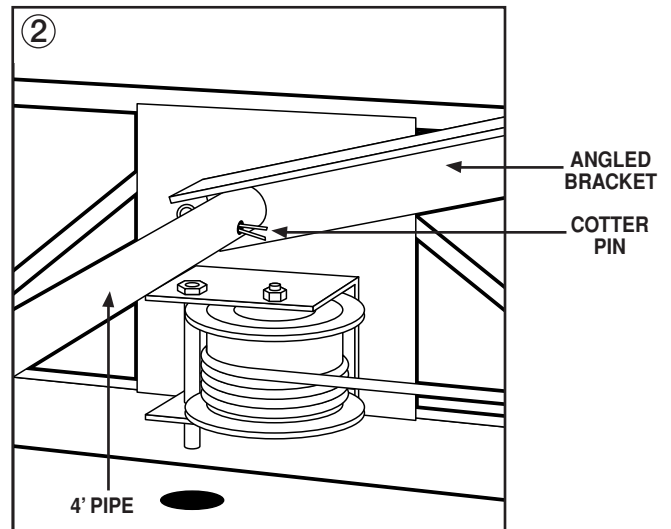

- Slide 4" pipe through the side plate on the dock, through the angled brace and the angled brace on opposite side of frame.
Note: Angle braces should face inward.
- Put one cotter key on outside of plate and one cotter key on inside of angled brace. Repeat on opposite side.

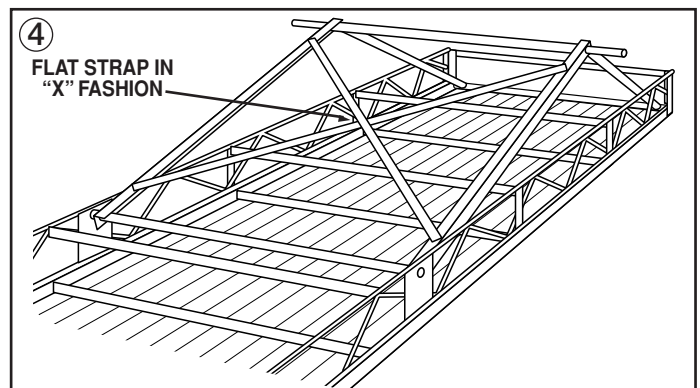

- Bolt the two flat straps in a x fashion onto the angle braces in the holes provided. Use 5/16" x 1" bolts and nuts.

"Quality Since 1971"

HEWITT MACHINE & MFG, INC. Box 111 Nicollet, MN 56074 (507) 225-3421

www.hewitt-roll-a-dock.com e-mail: info@hewitt-roll-a-dock.com

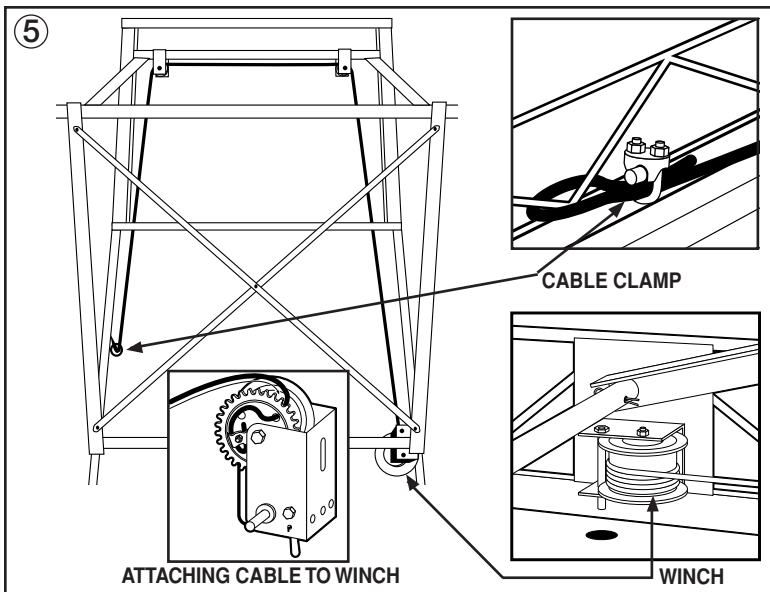

- Mount winch on side plate of dock with threaded shaft towards decking.
- Attach cable to winch drum using the winch bolt bag and illustration above.
- Thread cable from winch up to pulley sheaves at front corner, across other front corner, then straight down. Tie off with 1/4" cable clamps on side bridging across from where winch is mounted.
- Mount wheels onto axle pipe using a 2-1/2" washer and cotter pin on the outside of each tire.

7

- To install deck, start from middle of dock, making sure each side is flush.
- Drill up from bottom through hole in frame.
- Bolt down from top.

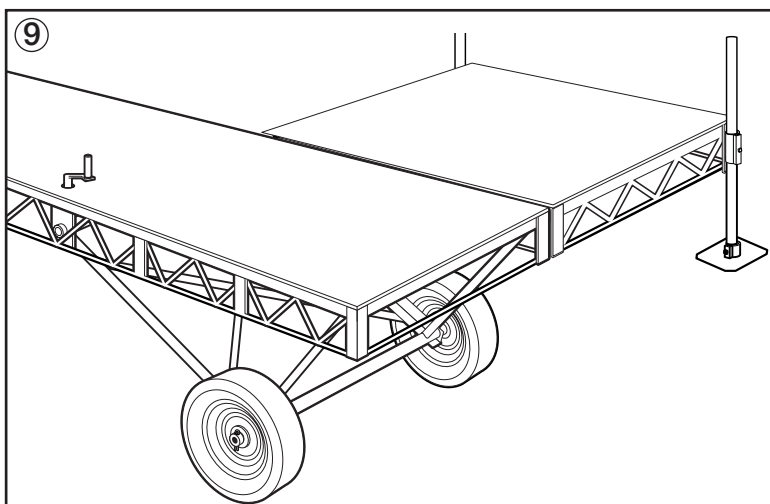

- Bolt on "L" or "T" sections as desired for final shape.
- Bolt on support stand brackets on corners
- Adjust stands after dock is in the water.

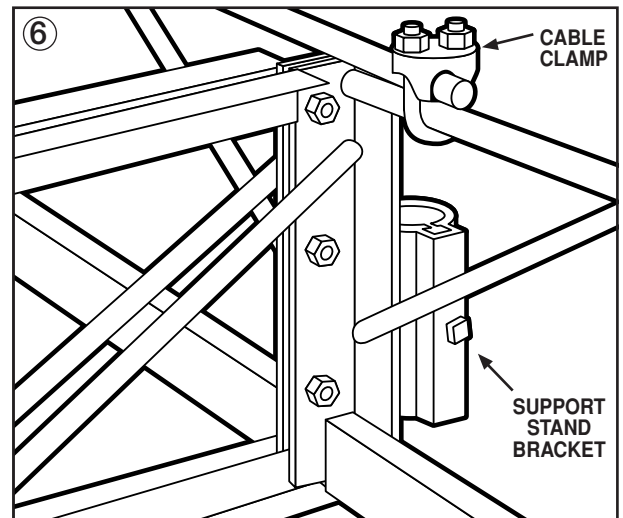

- Bolt dock sections together using cable clamps and bolts that are provided on the dock sections. If support stands are used, bolt them between sections now.

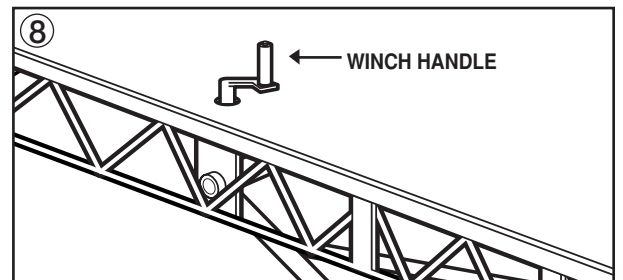

- Check all cable clamps and bolts making sure they are all tight.
Note: Make sure the pulley sheaves, on the wheel assembly, turn.
- Turn dock upright.
- To raise the height of dock grip winch handle firmly and turn it clockwise. If lowering dock grip winch handle firmly, before releasing the locking device, it will turn itself counter clockwise and lower quickly. Don't let go of handle until locking device is back in clicking position.
- Adjust height with winch when pushing dock into water.

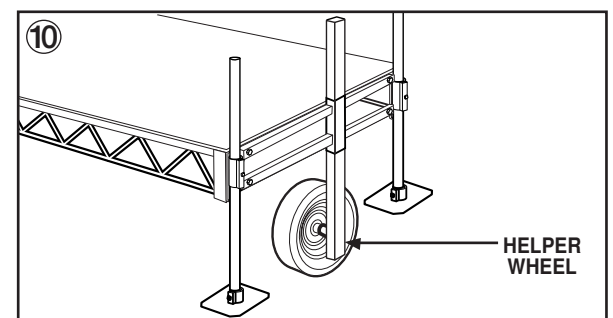

- Helper wheel for "L" shaped docks

"Quality Since 1971"

HEWITT MACHINE & MFG, INC. Box 111 Nicollet, MN 56074 (507) 225-3421

www.hewitt-roll-a-dock.com e-mail: info@hewitt-roll-a-dock.com